

Please read and save these instructions. Read carefully before attempting to assemble, install, operate or maintain the product described. Protect yourself and others by observing all safety information. Failure to comply with instructions could result in personal injury and/or property damage! Retain instructions for future reference.

Powerwinch®

Free Fall Rope and Chain Anchor Winch

Unpacking

When unpacking, inspect carefully for any damage that may have occurred during transit. Make sure any loose fittings, bolts, etc., are tightened before putting unit into service.

General Safety Information

▲ DANGER *Danger means a hazard that will cause death or serious injury if the warning is ignored.*

▲ WARNING *Warning means a hazard that could cause death or serious injury if the warning is ignored.*

▲ CAUTION *Caution means a hazard that may cause minor or moderate injury if the warning is ignored. It also may mean a hazard that will only cause damage to property.*

NOTE: Note means any additional information pertaining to the product or its proper usage.

The following safety precautions must be followed at all times:

1. Read all manuals included with this product carefully. Be thoroughly familiar with the controls and the proper use of the equipment. Only persons well acquainted with these rules of safe operation should be allowed to use the winch.



▲ DANGER *Never stand between load or anchor point and product. If rope breaks, it could snap with enough force to cause serious injury or death.*

▲ DANGER *Do not use electrical wire sizes or types other than those specified or included with this product.*



▲ DANGER *Always tie off the anchor to a secure mount while cruising to prevent anchor from breaking free.*

2. This product is intended to lift anchors. Never use product to lift or move people or animals.
3. Do not wear loose fitting clothing, scarves, or neck ties during operations of the product. Loose clothing may become caught in moving parts and result in serious personal injury or death.

▲ WARNING *Use supplied or recommended circuit breakers for safe installation. The warranty will be void and fire could result from using improper circuit breakers.*



4. Make sure area around anchor point is clear of people or objects before releasing or retrieving anchor.

▲ CAUTION *When product is not in use, anchor must be tied off onto a cleat to relieve motor tension and prevent boat damage. When trailing boat, anchor must be tied off.*

5. Never substitute cable for rope.

▲ WARNING *Always disconnect wiring harness from battery before attempting to install, service or relocate unit.*

6. Use of a davit with an open loop is not recommended with this product. Use a davit with a closed loop to prevent serious personal injury and/or property damage.

▲ WARNING *Never place any object in gypsy while retrieving or free-falling anchor. Serious injury could result.*

▲ CAUTION *Use only spliced rope and chain rodes. Shackles should not be used to secure rope to chain. Shackles will damage winch and could cause personal injury. Use of shackles will also void warranty.*

7. Stand away from product when in use and keep children away from product area at all times.

8. When replacing rope and chain, always use Powerwinch® brand or Powerwinch® certified rope and chain.

▲ CAUTION *Do not attempt to pull a load greater than rated load of product. Personal injury and/or property damage could occur.*

9. Do not operate product under the influence of alcohol and/or drugs.
10. Inspect entire rope for weak or worn condition or kinking (short tight twist or curl) before use. Replace worn or kinked rope for proper performance from product.
11. Inspect the entire chain for broken or bent links before use. Chain with bent or broken links should be replaced to obtain proper performance.

Installation

31', 36', 41' Class Anchor Winch

▲ DANGER *This product requires the use of a closed loop davit or bow roller. Davit or bow roller must be installed prior to installing anchor winch to ensure proper performance.*

To install anchor winch, refer to Figure 1 and the following instructions:

TOOLS REQUIRED (NOT INCLUDED):

1. Electric drill
2. 2 1/2" hole saw
3. 11/32" drill bit
4. 5/8" drill bit
5. Adjustable wrenches
6. Terminal crimping tool and wire cutter
7. Center punch
8. Hammer
9. Voltmeter

Installation (Cont'd)

MATERIAL REQUIRED (INCLUDED WITH ANCHOR WINCH):

1. Three 5/16"-18 stainless steel threaded rods. These rods secure anchor winch to boat. Length is determined by thickness of boat deck.
2. Three lock washers (5/16" stainless steel)
3. Three plain washers (5/16" stainless steel)
4. Three nuts (5/16"-18 stainless steel)

MATERIAL REQUIRED (NOT INCLUDED):

NOTE: A wiring kit from Powerwinch® (Part No. P55800) is available which contains items 2-13.

1. Marine plywood for under deck support (optional)
2. Six 1/4"- 20 x 1/2" hex head stainless steel screws
3. Six 1/4"- 20 x 1/2" stainless steel nuts
4. Ten 5/16" 8-gauge ring terminals
5. #12 AWG red wire class 105°C
6. #12 AWG black wire class 105°C
7. Four 5/16" 12-gauge ring terminals
8. #8 AWG black wire class 105°C (6-gauge 40')
9. #8 AWG red wire class 105°C (6-Gauge 40')
10. 1" diameter heat shrink tubing
11. 2" diameter heat shrink tubing
12. Wire ties
13. Four 12-gauge insulated female

- disconnects
14. Silicone sealer
15. Loctite® 242 thread locker (optional)

MOUNTING ANCHOR WINCH ONTO DECK

1. Place mounting template in desired position on deck and secure with tape into position. Ensure center-line of gypsy lines up with centerline of davit or bow roller.

IMPORTANT: Be certain anchor winch is positioned above rope locker before drilling any mounting holes. The anchor line and chain will feed into rope locker through a 2 1/2" hole in boat deck and a molded part called the rode glide. Minimum rope locker dimensions required for proper storage of anchor lines are shown in Chart 1.

2. Using a punch, mark center of each

Line Dimensions	Locker Dimensions (L x W)
1/2" x 200'	15" x 17"
1/2" x 300'	15" x 24"
5/8" x 200'	15" x 24"
5/8" x 300'	16" x 32"

Chart 1

mounting hole to be drilled. Remove template and drill holes with an electric drill. There are three 11/32" holes for mounting studs, one 2 1/2" hole for deck insert, and one 5/8" hole for wiring harness.

3. Place round side of insert into 2 1/2" hole and seat deck insert so lip is flush with boat deck. The half circle portion

of deck insert must be pointing toward bow of boat.

4. Insert three mounting studs into threaded holes on underside of winch. A small amount of thread locker can be used to secure studs in housing. Use two mounting nuts to help tighten studs into housing as shown in Figure 2.
5. Gently guide winch over rode glide so loop on anchor winch housing slides over deck insert. Slide three mounting studs into the three mounting holes

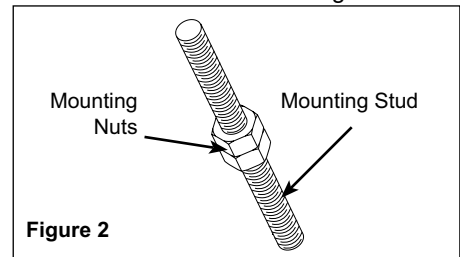

Figure 2

in deck. Feed wiring harness from underside of winch through 5/8" hole.

6. The winch must fit squarely over deck insert and onto deck. Slide flat washers and lock washers onto mounting studs. Tighten nuts to fully secure the winch to the deck.
7. Examine winch to make sure unit is securely fastened and that centerline of gypsy is aligned with centerline of bow roller or davit.

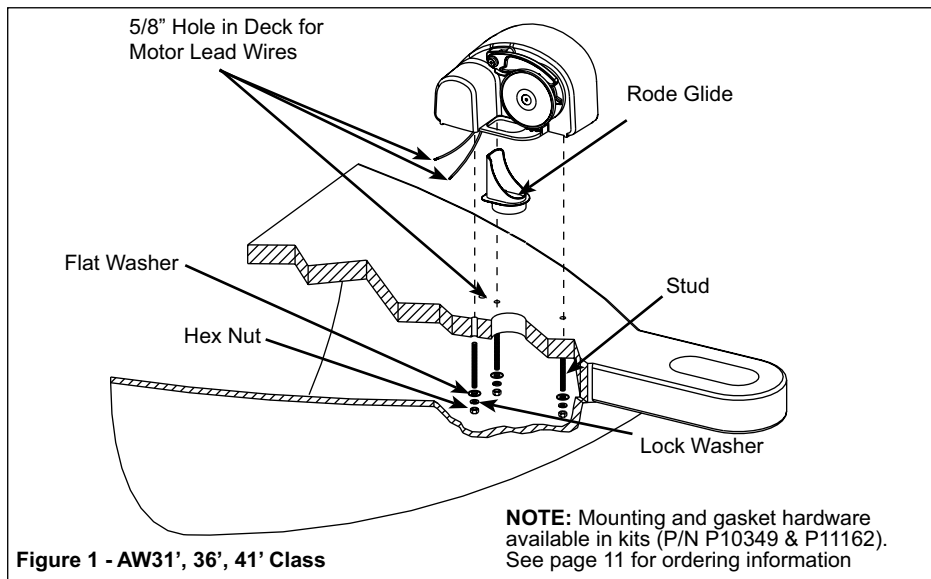

Figure 1 - AW31', 36', 41' Class

NOTE: Mounting and gasket hardware available in kits (P/N P10349 & P11162). See page 11 for ordering information

Wiring Installation

WIRING AND SWITCH INSTALLATION

⚠ CAUTION

Do not use electrical wire sizes or types other than those specified or included with this product.



⚠ DANGER

Use supplied or recommended circuit breakers for safe installation. The warranty will be void and fire can result from using improper circuit breakers.



Installation (Cont'd)

⚠ WARNING Always disconnect wiring harness from battery before attempting to install, service or relocate unit.

⚠ CAUTION Follow order of wiring steps to ensure power is not applied to anchor winch until all wires and circuit breakers are installed.

⚠ WARNING Always keep wires away from intense sources of heat. Be sure newly installed wires are away from any exposed bare wires.



SWITCH INSTALLATION

⚠ DANGER Make sure all crimps/connections can withstand at least 25 pounds of pullout force. Failure to make strong enough crimps between wire connectors and wires could create a fire hazard.



1. Select a suitable location (console, etc.) to locate switch. Make sure there is enough room behind switch mounting surface for entire switch and wires.
2. Cut a hole 1 3/4" high and 1" wide.
3. Apply a thin bead of silicone sealer around edge of switch mounting plate

4. Measure and cut 8-gauge red and black wire to run from anchor winch to switch. Allow some slack to prevent connections from being too short and so connections can be crimped to end of wire. Install wire in boat before crimping any connections. Cable ties can be used to secure wiring to boat.
5. When running wire from anchor winch to switch, be sure to keep wire away from sources of intense heat or areas where the insulation of wire could be worn away.
6. After wire is installed and secured, connection to anchor winch can be made.
7. Crimp a 5/16" ring terminal to 8-gauge red wire just cut.
8. Using a 1/4"-20 x 1/2" screw, connect 8-gauge red wire to ring terminal on the green wire coming from anchor winch. Tighten a 1/4"-20 nut to secure ring terminals together. Protect junction by placing a 1" diameter piece of heat shrink tubing over connection and applying heat until tubing is secure.
9. Crimp a 5/16" ring terminal to 8-gauge black wire just cut.
10. Using a 1/4"-20 x 1/2" screw, connect 8-gauge black wire to ring terminal on black wire coming from anchor winch. Tighten a 1/4"-20 nut to secure ring

terminals together. Protect junction by placing a 1" diameter piece of heat shrink tubing over connection and applying heat until the tubing is secure.

SWITCH TO ANCHOR WINCH

The switch needs 12-gauge wire connections and wiring just run is 8-gauge. To complete anchor winch to switch connections construct two conversion wires by following these steps:

1. This switch wire is for the positive (red) lead.
2. Cut a 1 foot section of 12-gauge red wire and crimp a 5/16" ring terminal to one end.
3. Crimp an insulated female disconnect to other end.
4. Crimp a 5/16" ring terminal to 8-gauge red wire coming from anchor winch.
5. Using a 1/4"-20 x 1/2" screw, connect 8-gauge red wire coming from anchor winch to ring terminal on red switch wire. Tighten a 1/4"-20 nut to secure ring terminals together. Protect junction by placing a 1" diameter piece of heat shrink tubing over connection and applying heat until tubing is secure.
6. Plug insulated female disconnect on end of red switch wire to rocker switch on terminal marked "A".
7. To construct second switch wire and make connection to switch, cut a 1 foot section of 12-gauge black wire and crimp a 5/16" ring terminal to one end.
8. Crimp an insulated female disconnect to other end.
9. Crimp a 5/16" ring terminal to 8-gauge black wire coming from anchor winch.
10. Using a 1/4"-20 x 1/2" screw, connect 8-gauge black wire coming from anchor winch to ring terminal on black switch wire. Tighten a 1/4"-20 nut to secure ring terminals together. Protect junction by placing a 1" diameter piece of heat shrink tubing over connection and applying heat until tubing is secure.
11. Plug insulated female disconnect on end of black switch wire to rocker switch on terminal marked "B".

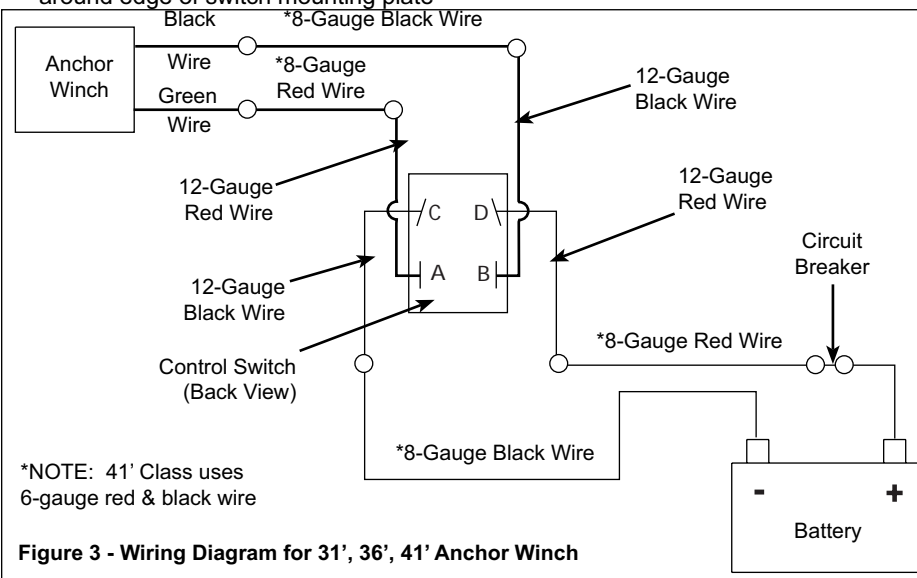

Installation (Cont'd)

SWITCH TO BATTERY

⚠ DANGER



Make sure all crimps/connections can withstand at least 25 pounds of pullout force. Failure to make strong enough crimps between wire connectors and wires could create a fire hazard.

1. Measure and cut 8-gauge red and black wire to run from switch to battery. Allow some slack to prevent connections being too short leaving enough room to crimp end of wire. Install wire in boat before crimping any connections. Use cable ties to secure wiring to boat.
2. When running wire from switch to battery, be sure to keep wire away from sources of intense heat or areas where insulation of wire could be worn away.
3. After wire is installed and secured, make remaining switch connections .
4. Make two more conversion wires to attach battery wiring to switch by following these steps:
 - a. This switch wire is for the positive (red) lead to battery.
 - b. Cut a 1 foot section of 12-gauge red wire and crimp a 5/16" ring terminal to one end.
 - c. Crimp an insulated female disconnect to other end.
 - d. Crimp a 5/16" ring terminal to 8-gauge red wire coming from battery.
 - e. Using a 1/4"-20 x 1/2" screw, connect 8-gauge red wire coming from battery to ring terminal on red switch wire. Tighten a 1/4"-20 nut to secure ring terminals together. Protect junction by placing a 1" diameter piece of heat shrink tubing over connection and applying heat until tubing is secure.
 - f. Plug insulated female disconnect on end of red switch wire to rocker switch on terminal marked "D".
 - g. To construct second switch wire and make connection to switch, cut a 1 foot section of 12-gauge black wire and crimp a 5/16" ring terminal to one end.
 - h. Crimp an insulated female disconnect to other end.
 - i. Crimp a 5/16" ring terminal to 8-gauge black wire coming from battery.
 - j. Using a 1/4"-20 x 1/2" screw, connect 8-gauge black wire coming from battery to ring terminal on black switch wire. Tighten a 1/4"-20 nut to secure ring terminals together. Protect junction by placing a 1" diameter piece of heat shrink tubing over connection and applying heat until tubing is secure.
 - k. Plug insulated female disconnect on end of black switch wire to rocker switch on terminal marked "C".

BATTERY CONNECTIONS

1. Crimp a 5/16" ring terminal to end of 8-gauge red and black wire coming from switch.
2. Create a jumper to connect circuit breaker to battery by cutting a 1 foot piece of 8-gauge red wire and crimping a 5/16" ring terminal to each end.
3. Assemble circuit breaker to jumper by placing ring terminal onto post marked "bat" and secure with nut on circuit breaker
4. Assemble circuit breaker to switch by attaching remaining 8-gauge wire to post on circuit breaker marked "aux."
5. Protect connection by placing a piece of 2" diameter heat shrink tubing over connection and applying heat until tubing is secure.
6. Connect 8-gauge black wire from switch to negative (-) battery terminal.
7. Connect 8-gauge black wire from switch to negative (+) battery terminal.
8. Snap control switch into switch plate and proceed to unit test instructions.

UNIT TEST

1. With no rope or chain in gypsy, press switch in upward position. If wiring to switch terminals is correct, gypsy will spin counterclockwise.
2. If gypsy does not turn, but motor runs, switch is incorrectly wired.

3. To correct, exchange wires at terminals A and B on switch.

46' Class Anchor Winch

⚠ DANGER

This product requires use of a

closed loop davit or bow roller. The davit or bow roller must be installed on boat prior to installing product to ensure proper performance.

To install anchor winch, refer to Figure 4 and the following instructions:

TOOLS REQUIRED (NOT INCLUDED):

1. Electric drill
2. 2 1/2" hole saw
3. 11/32" drill bit
4. 5/8" drill bit
5. Adjustable wrenches
6. Terminal crimping tool and wire cutter
7. Center punch
8. Hammer
9. Voltmeter

MATERIAL REQUIRED (INCLUDED WITH ANCHOR WINCH):

1. Three 5/16"-18 stainless steel threaded rods. These rods secure anchor winch to boat. Length is determined by thickness of boat deck.
2. Three lock washers (5/16" stainless steel)
3. Three plain washers (5/16" stainless steel)
4. Three nuts (5/16"-18 stainless steel)

MATERIAL REQUIRED (NOT INCLUDED):

NOTE: A wiring kit from Powerwinch® (Part No. P10284) is available which contains items 2-15.

1. Marine plywood for under deck support (optional)
2. Six 3/8" 6-gauge ring terminals
3. #6 AWG red wire class 105°C
8. #6 AWG black wire class 105°C
4. Two 5/16" 16-gauge ring terminals
5. #16 AWG black wire class 105°C
6. #16 AWG white wire class 105°C
7. #16 AWG red wire class 105°C
8. Six 16-gauge insulated female disconnects
9. Two 1/4"-20 x 1/2" stainless steel hex head screw

Installation (Cont'd)

10. Two 1/4"-20 x 1/2" stainless steel nuts
11. 1" diameter heat shrink tubing
12. 2" diameter heat shrink tubing
13. ATO inline fuse holder
14. 10A ATO style fuse
15. Wire ties
16. Loctite® 242 thread locker (optional)
17. Silicone sealer
18. four 3/8" 6-gauge female disconnects

LOCATING MOUNTING HOLES FOR ANCHOR WINCH

1. Place mounting template in desired position on deck and secure with tape into position. Ensure center-line of gypsy lines up with centerline of davit or bow roller.

IMPORTANT: Be certain anchor winch is positioned above rope locker before drilling any mounting holes. The anchor line and chain will feed into rope locker through a 2 1/2" hole in boat deck and a molded part called deck insert. Minimum rope locker dimensions required for proper storage of anchor lines are shown in Chart 2.

2. Spot holes with center punch as shown on template. Use an electric drill to drill holes. There are three 1 1/32" holes for mounting studs, one 2 1/2" hole for deck insert, and one 5/8" hole for wiring harness.
3. Place round side of insert into 2 1/2" hole and seat deck insert so lip is flush with

Line Dimensions	Locker Dimensions (L x W)
1/2" x 200'	15" x 17"
1/2" x 300'	15" x 24"
5/8" x 200'	15" x 24"
5/8" x 300'	16" x 32"

Chart 2

boat deck. The half circle portion of deck insert must be pointing toward bow of boat.

4. Insert three mounting studs into threaded holes on underside of winch. A small amount of thread locker can be used to secure studs in housing. Use two mounting nuts to help tighten studs into housing as shown in Figure 5.
5. Gently guide winch over rode glide

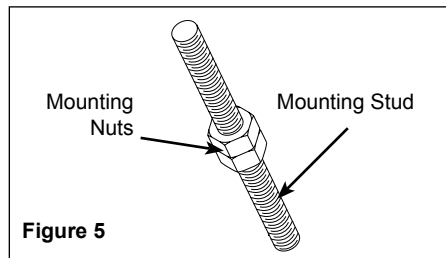

Figure 5

so loop on anchor winch housing slides over rode glide. Slide three mounting studs into three mounting holes in deck. Feed wiring harness from underside of winch through 5/8" hole.

6. The winch must fit squarely over deck insert and onto deck. Slide flat washers and lock washers onto

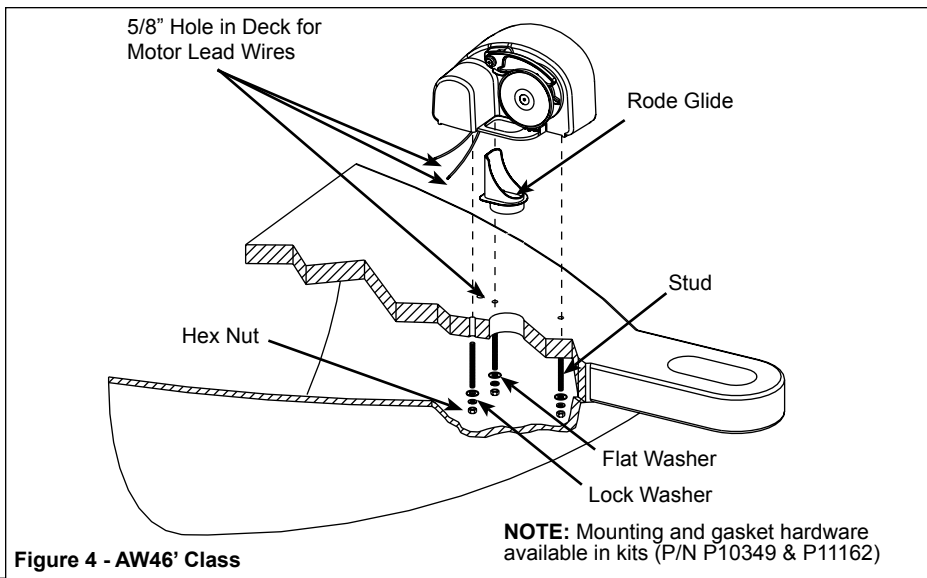

Figure 4 - AW46' Class

mounting studs. Tighten nuts to fully secure winch to deck.

8. Examine winch to make sure unit is securely fastened and that center-line of gypsy is aligned with centerline of bow roller or davit.

WIRING AND SWITCH INSTALLATION

CAUTION

Do not use electrical wire sizes or types other than those specified or included with this product.



DANGER

Use supplied or recommended circuit breakers for safe installation. The warranty will be void and fire could result from using improper circuit breakers.



WARNING

Always disconnect wiring harness from battery before attempting to install, service or relocate unit.

CAUTION

Follow order of wiring steps to ensure power is not applied to anchor winch until all wires and circuit breakers are installed.

WARNING

Always keep wires away from intense sources of heat. Be sure newly installed wires are away from any exposed bare wires.



SWITCH AND SOLENOID LOCATION

1. Select a suitable location (console, etc.) to locate switch. Make sure there is enough room behind switch mounting surface for entire switch and wires.
2. Cut a hole 1 3/4" high and 1" wide.
3. Apply a thin band of silicone sealer around edge of switch mounting plate and attach plate using four #8 round head wood screws.
4. Select a suitable location for relay (reversing switch). Locate reversing switch within 6-8 feet of switch plate and in a location away from exposure to water. Mount relay with power terminals facing up.

Installation (Cont'd)

WIRING ANCHOR WINCH TO RELAY (REFER TO FIGURE 6)

⚠ DANGER

Make sure all crimps/connections can withstand at least 25 pounds of pullout force. Failure to make strong enough crimps between wire connectors and wires could create a fire hazard.



1. Measure and cut 6-gauge red and black wire to run from anchor winch to relay. Allow some slack to prevent connections being too short leaving enough room to crimp end of wire. Install wire in boat before crimping any connections. Use cable ties to secure wiring to boat.
2. When running wire from anchor winch to relay, be sure to keep wire away from sources of intense heat or areas where insulation of wire could be worn away. Cable ties can be used to secure wiring to boat.
3. After wire is installed and secured, connection to anchor winch can be made.
4. Crimp 3/8" ring terminals to 6-gauge red and black wire connected to anchor winch.
5. Attach 6-gauge red wire to red wire coming from anchor winch. Secure junction by placing a 1/4"-20 x 1/2"

screw through ring terminals and tighten a 1/4"-20 nut on screw. Protect junction by placing a 1" diameter piece of heat shrink tubing over connection and applying heat until tubing is secure.

6. Attach 6-gauge black wire to black wire coming from anchor winch. The junction can be secured in same manner as 6-gauge red wire in step 5.
7. The connections at relay from anchor winch can now be made.
8. Crimp 3/8" female disconnects to red and black wires to be attached to relay.
9. Connect 6-gauge red wire to relay on post marked M1 and secure by tightening supplied nut.
10. Connect 6-gauge black wire to relay on post marked M2 and secure by tightening supplied nut.

WIRING SWITCH TO RELAY

⚠ DANGER

Make sure all crimps/connections can withstand at least 25 pounds of pullout force. Failure to make strong enough crimps between wire connectors and wires could create a fire hazard.



1. Measure a 16-gauge red, white, and black wire to run from switch to relay. Allow some slack to prevent connections being too short leaving enough room to crimp end of wire.

Install wire in boat before crimping any connections. Use cable ties to secure wiring to boat.

2. When running wire from switch to relay, be sure to keep wire away from sources of intense heat or areas where insulation of wire could be worn away. Cable ties can be used to secure wiring to boat.
3. Once wires are run and secured, connect wires from switch to relay.
4. Starting on the wire ends for switch, crimp one 16-gauge insulated female disconnect to red wire.
5. Plug red wire into middle post on back of switch.
6. Next, crimp a 16-gauge insulated female disconnect to white wire.
7. Plug white wire into top post on back of switch.
8. Crimp a 16-gauge insulated female disconnect to black wire.
9. Plug black wire into bottom post on back of switch.
10. Make connections at relay.
11. Crimp a 16-gauge insulated female disconnect to white wire.
12. Plug white wire into terminal marked S1 on the relay.
13. Crimp a 16-gauge insulated female disconnect to black wire.
14. Plug black wire into terminal marked S2 on relay.
15. Using a 16-gauge butt connector, connect fuse holder to red wire.
16. Crimp a 16-gauge insulated female disconnect to remaining open end of fuse holder.
17. Attach fuse holder with disconnect crimped to it to terminal marked S3 on relay.
18. Insert 10 amp ATO style fuse in fuse holder.

WIRING RELAY TO BATTERY

⚠ DANGER

Make sure all crimps/connections can withstand at least 25 pounds of pullout force. Failure to make strong enough crimps between wire connectors and wires could create a fire hazard.



1. Measure 6-gauge red and black wire to run from relay to battery. Allow

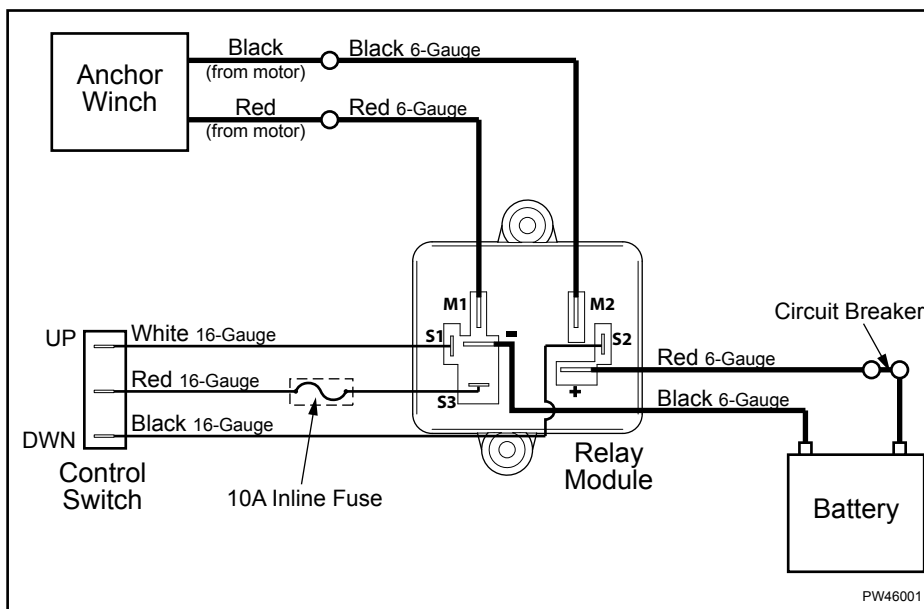

Installation (Cont'd)

- some slack to prevent connections being too short leaving enough room to crimp end of wire. Install wire in boat before crimping any connections. Use cable ties to secure wiring to boat.
2. When running wire from solenoid to battery, keep wire away from sources of intense heat or areas where insulation of wire could be worn away.
 3. Once wires are run and secured, connect wires from switch to solenoid.
 4. Crimp 3/8" ring terminals to 6-gauge red and black wire to be connected to solenoid.
 5. Attach 6-gauge red wire to post marked "+" on solenoid. Secure with supplied nut.
 6. Attach 6-gauge black wire to post marked "-" on solenoid. Secure with supplied nut.
 7. Attach end of the jumper with ring terminal to terminal marked "-" on solenoid.
 8. At end of 6-gauge red wire coming from solenoid, crimp a 3/8" ring terminal.
 9. At end of 6-gauge black wire coming from solenoid, crimp a 3/8" ring terminal.
 10. Create a jumper to connect circuit breaker to battery by cutting a 5/16" ring terminal to each end.
 11. Attach circuit breaker to jumper just created by securing post marked "bat" through one of the ring terminals. Secure with nut on circuit breaker post.
 12. Attach remaining 6-gauge red wire
- coming from the solenoid on circuit breaker to post. The post on circuit breaker marked "aux" must be connected to this wire.
13. Protect connection by placing a piece of 2" diameter heat shrink tube over connection and applying heat until tubing is secure.
 14. The 6-gauge black wire from solenoid can now be connected to negative (-) battery terminal.
 15. The 6-gauge red wire with circuit breaker can now be connected to positive (+) battery terminal.
 16. The connections are now complete.
 17. Snap control switch into switch plate and proceed with unit test instructions.

UNIT TEST

1. Without rope or chain in gypsy, press and hold switch in upward position. If wiring to switch terminals is correct, gypsy will spin counterclockwise.
2. If gypsy does not turn, but motor runs, switch is incorrectly wired.
3. To correct, exchange locations of black and white wires on back of switch.
4. If motor does not run, check to make sure fuse has been installed in fuse holder located in 16-gauge red switch wire.

Anchoring Instructions

LOADING ROPE AND CHAIN

⚠ WARNING Use of rope NOT specified by Powerwinch® could cause unit or property damage or personal injury and will void warranty.

1. Feed rope through davit or bow roller and pull toward anchor winch. Make sure rope is not twisted or kinked and can freely run through bow roller or davit.
2. Lift finger and insert rope into rode glide and down into rope locker. Allow enough slack so rope can be tied off in rope locker.
3. Release finger and make sure rope is firmly seated in the gypsy.
4. Go below to rope locker and tie rope off.
5. Press switch up and begin retrieving rope and chain into rope locker.

USING PROPER ROPE AND CHAIN

This product is a uniquely designed device to raise and lower anchors using spliced rope and chain rodes (a rode is a length of rope and chain). It is very important that only sizes and brands of spliced rope and chain rodes specified by Powerwinch® are used in this product. Use of non-specified ropes and chains could cause reduced levels of performance or serious personal injury and/or property damage. Use of non-specified ropes and chains will also invalidate the product warranty. The ropes and chain rodes specified for this anchor winch are shown on page 7 in Chart 3. Once an anchoring spot and depth is determined, anchor may be released.

Powerwinch® Recommended Rope and Chain		
Product Model	Required Rope	Required Chain
31'/36' Class	1/2" diameter, three strand, medium lay, premium nylon Powerwinch® rope or New England Rope	1/4" Acco G4 Hi-Test chain. Failure to use recommended chain will invalidate the warranty of the product
41'/46' Class	5/8" diameter, three strand medium lay, premium nylon Powerwinch® rope or New England Rope	5/16" Acco G4 Hi-Test chain. Failure to use recommended chain will invalidate the warranty of the product

FAILURE TO USE RECOMMENDED ROPE AND CHAIN WILL VOID PRODUCT WARRANTY

Chart 3 - Recommended Rope and Chain

ANCHORING

- Turn boat into wind and place motor(s) in neutral.
- After boat has stopped all forward progress, drop anchor by pressing anchor winch switch to down position for five seconds.
- The anchor will release from bow roller or davit and free-fall to sea bed. Once anchor has begun free-falling, it is safe to release switch.

▲ CAUTION *After desired amount of scope has been released from anchor winch, retrieve 3-5 feet of line with anchor winch by pressing switch to up position.*

- Place boat's motor(s) in neutral and allow boat to drift back and set anchor in sea bed.

▲ CAUTION *Tie off anchor line to a deck cleat. Do NOT use anchor winch to tie off anchor.*

Unit Operation

RETRIEVING THE ANCHOR

- Untie anchor line from deck cleat.
- To retrieve anchor, align bow of boat with anchor rode.
- Place motor(s) in forward and move boat slowly toward anchor point. While moving, press anchor winch switch up and retrieve anchor rode.

▲ CAUTION *Do NOT pull boat to anchor point solely with anchor winch. The anchor winch's gear train or motor could suffer damage. The boat's motor MUST be used to move boat toward anchor point.*

- When chain begins entering gypsy, this is an indication that the rode is almost retrieved. Take care to prevent anchor from being pulled up too quickly into davit or bow roller.
- When anchor enters davit or bow roller, do not place too much tension on chain between anchor winch and anchor. This could cause damage to gypsy or davit. It may also degrade free-fall performance on next anchor drop.

▲ CAUTION *Never use anchor winch to break anchor free. Never reverse anchor winch*

while unit is in free-fall.

ANCHOR RELEASE (FREE-FALL)

To release anchor, push switch to down position and hold for 5 seconds. The unit will disengage and anchor will fall freely. When sufficient line has been released and gypsy has stopped turning, push switch to up position and pull in slack on rode.

To retrieve anchor, push switch to up position. When anchor is in bow roller or davit, release switch. Make sure anchor is secured in davit or bow roller.

Maintenance

1. Following each boat outing, flush exterior of winch with fresh water. Use only mild detergents to clean exterior. Use of solvents may cause damage and reduce effectiveness of corrosion resistant parts, paint and gaskets, as well as void product warranty.
2. Every 6 months inspect gypsy, stripper, finger and deck insert for wear. Replace any worn components.
3. Check electrical connections every 6 months for corrosion. Replace any connection or wire which is damaged, corroded, frayed or worn.
4. Check rope periodically for abrasion or deep cuts. Never splice an old rope with a new rope. If replacement is necessary, use only Powerwinch® rope specifically designed for this product.
5. Check chain periodically for bent links and corrosion. Damaged links can become jammed in gypsy or damage stripper and finger. Use of damaged chain will void warranty.

Technical Service

For information regarding operation or repair of this product, please call 800-243-3097 for assistance.

Troubleshooting Guide

Symptom	Possible Cause(s)	Corrective Action
Product will not operate	<ol style="list-style-type: none"> 1. Disconnected, bad wiring or bad circuit breakers 2. 10A fuse not in fuse holder or burned out (AW46' only) 	<ol style="list-style-type: none"> 1. Check each connection with a voltmeter and with switch engaged. Check circuit breaker connection closely 2. Replace fuse
Rope slips or jams when retrieving	<ol style="list-style-type: none"> 1. Wrong rope size 2. Rope is frayed and worn 3. Rope is too stiff 	<ol style="list-style-type: none"> 1. Replace rope with Powerwinch® certified 1/2" or 5/8" rope 2. Replace rope 3. Replace rope
Chain slips or jams when retrieving or free falling	<ol style="list-style-type: none"> 1. Wrong chain size 2. Chain links are bent or corroded 3. Chain is kinked 	<ol style="list-style-type: none"> 1. Replace chain with Powerwinch® certified 1/4" or 5/16" Acco G4 High Test chain 2. Replace chain 3. Unkink chain
Anchor line will not free-fall	<ol style="list-style-type: none"> 1. Rope tangled in rope locker 2. Chain is kinked 3. Anchor is wedged in bow roller 	<ol style="list-style-type: none"> 1. Be sure rope is not kinked or twisted before anchoring 2. Unkink chain 3. Free anchor

LIMITED WARRANTY

- A. This Limited Warranty is given by the Powerwinch Division of the Scott Fetzer Company (the "Company") to the original purchaser (the "Purchaser") of a Powerwinch Product (the "Product") specified in this manual. This Limited Warranty is not transferable to any other party.
- B. Responsibilities of the Company under this Limited Warranty:
 1. Repair or replace (at the discretion of the Company) any part or parts of the Product found by the Company to be defective within a 2 year (AW31'), 3 year (36'/41'/46') period from the date of purchase.
 2. The Company will pay the transportation charge for shipment back to the Purchaser of any Product received for legitimate Warranty repair.
- C. Responsibilities of the Purchaser under this Limited Warranty:
 1. Complete (fully and accurately) and return to the Company, the Warranty card included in the box. Otherwise, Purchaser will have to show dated proof of purchase to qualify for service under the provisions of the Limited Warranty.
 2. Promptly notify the Seller or the Company of any claim hereunder.
 3. Use reasonable care in maintenance, operation, use and storage of the Product in accordance with the instructions contained in the Owner's Manual.
 4. Have Warranty work performed by an authorized Powerwinch warranty repair center or representative approved by the Company.
 5. Except as noted in B.2., transportation charges are the responsibility of the Purchaser.
- D. This Limited Warranty covers:
 1. Defects in workmanship or materials.
 2. Any part or parts of the Product sold or manufactured by the Company.
- E. This Limited Warranty does not cover:
 1. Any failure that results from improper installation of the Product.
 2. Any failure that results from accident, Purchaser's abuse, neglect, modification, improper maintenance, or failure to operate and use the Product in accordance with the instructions provided in the Owner's Manual supplied with the Product.
- F. There is no other express warranty. Implied warranties, including those of merchantability and fitness for a particular purpose, are limited to one (1) year from date of purchase. This is the exclusive remedy and any liability for any and all incidental or consequential damages or expenses whatsoever is excluded. Some states do not allow limitations on how long an implied warranty lasts, or do not allow exclusion or limitation of incidental or consequential damages, the above limitations may not apply to you.

Do Not Return Your Product To The Factory. Unauthorized Returns Will Delay Repair of Your Product and Incurr Additional Shipping Charges to You.

This Limited Warranty gives you specific legal rights, and you may also have other rights which vary from state to state. Powerwinch reserves the right to alter specifications on any product without notice. All rights reserved. This publication or parts thereof may not be reproduced in any form without written permission.

For Replacement Parts, Call 1-800-243-3097

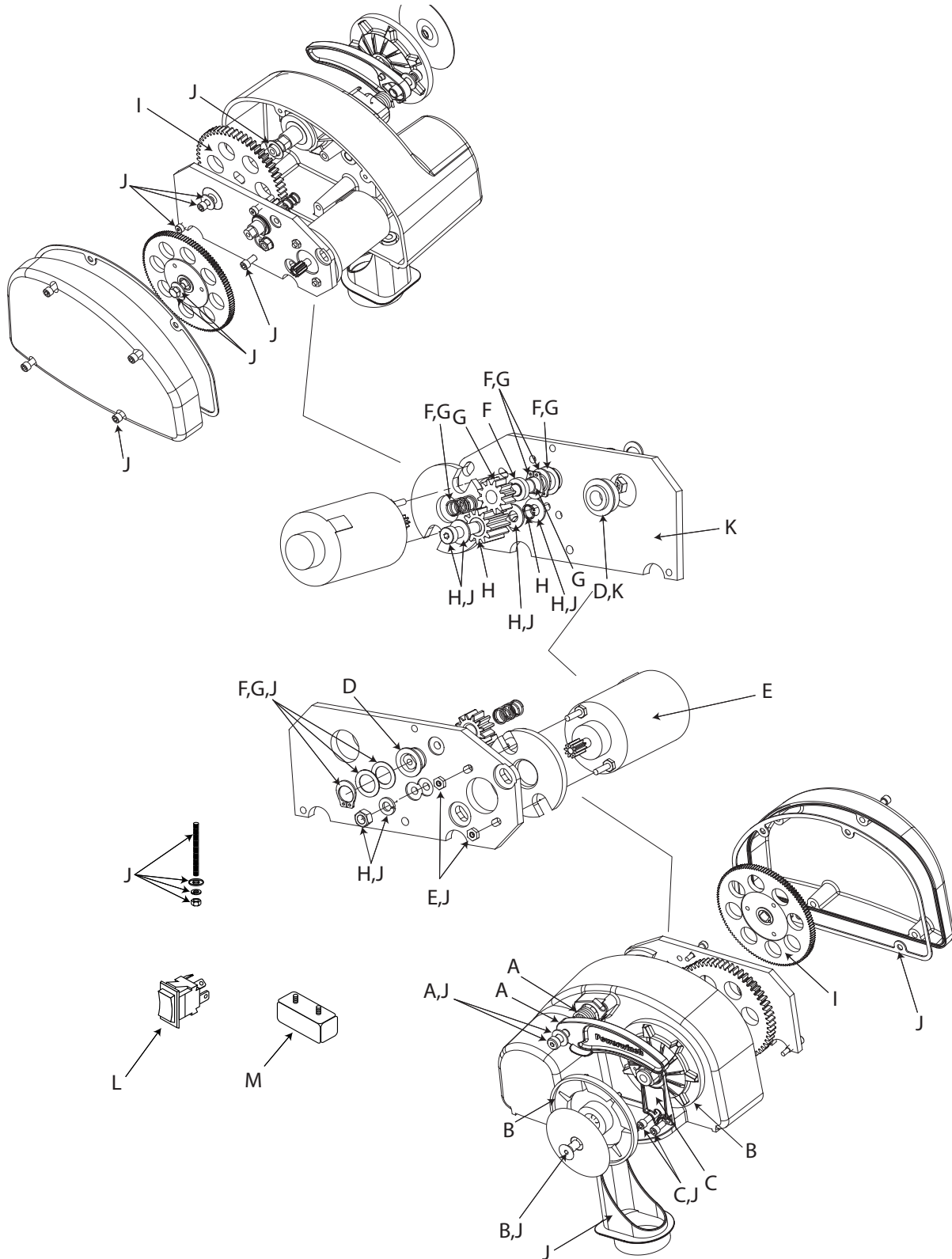

Figure 7 - Replacement Parts Illustration for 31', 36', 41' Class Anchor Winch

For Replacement Parts, Call 1-800-243-3097

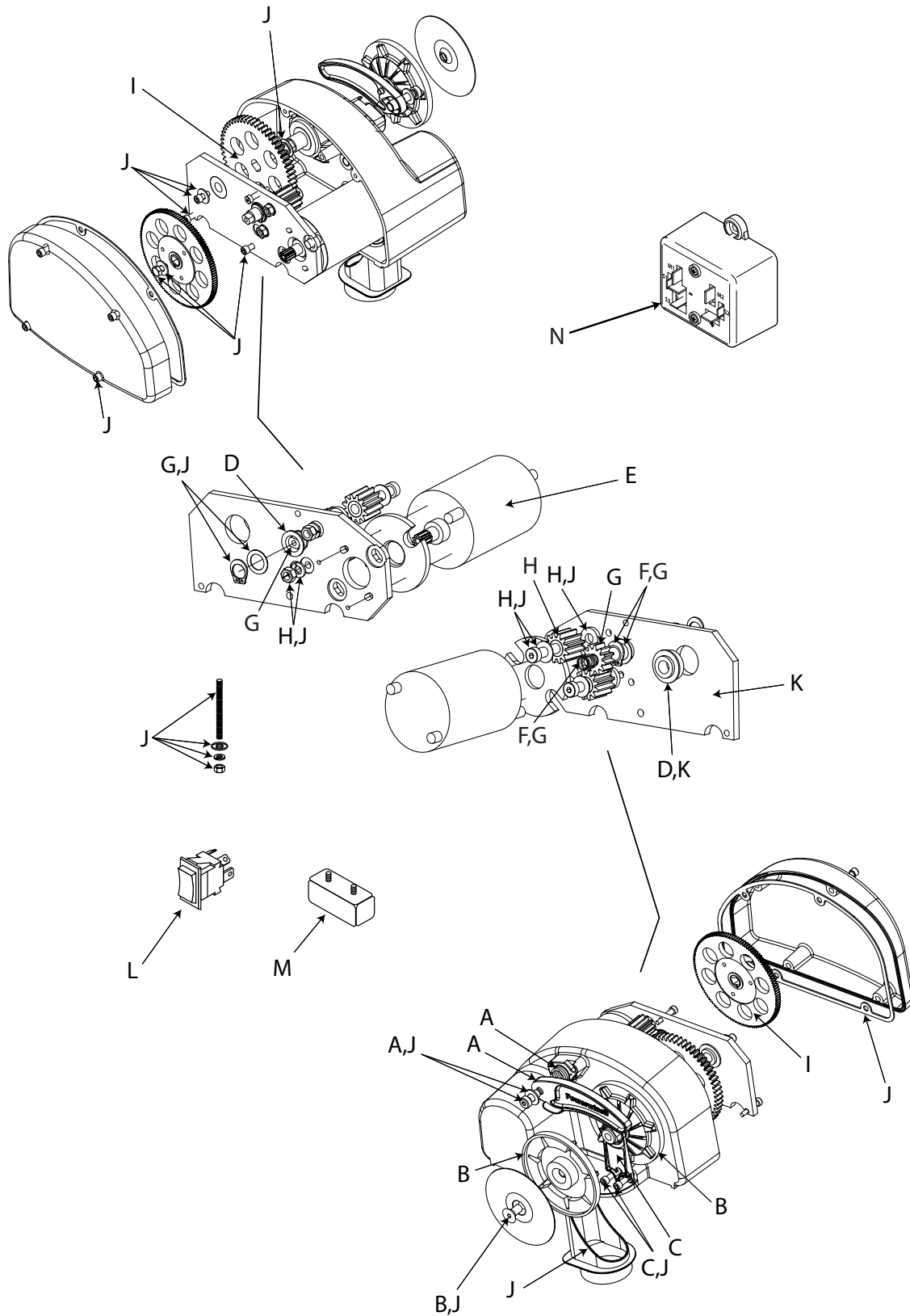

Figure 8 - Replacement Parts Illustration for 46' Class Anchor Winch

For Replacement Parts, Call 1-800-243-3097

Please provide following information:

- Model number
- Serial number (if any)
- Part description and number as shown in parts list

Address parts correspondence to:

Carefree/Powerwinch
2145 West 6th Street
Broomfield, CO 80020.

Ref. Letter	Description	31' Class	36' Class	41' Class	46' Class
A	Replacement Finger Kit	R001430	R001443	R001443	R001443
B	Replacement Gypsy Kit	R001431	R001431	R001449	R001449
C	Replacement Stripper Kit	R001432	R001432	R001432	R001432
D	Replacement Bearing Kit	R001433	R001433	R001433	R001443
E	Replacement Motor Kit	R001434	R001434	R001434	R001450
F	Replacement Shock Absorber Kit	R001435	R001435	R001435	-
G	Replacement Spinoff Gear/Shaft Kit	R001436	R001436	R001436	R001446
H	Replacement Locking Gear Kit	R001437	R001437	R001437	R001445
I	Replacement Gear Kit	R001438	R001438	R001438	R001438
J	Replacement Fastener Kit	R001439	R001439	R001439	R001444
K	Replacement Motor Plate Kit	R001440	R001440	R001440	R001440
L	Replacement Switch Kit	R001441	R001441	R001441	R001447
M	Replacement Circuit Breaker Kit	P1027600AJ	P1027600AJ	P1027600AJ	P1064800AJ
N	Replacement Relay Kit	-	-	-	P1028200AJ

